

TIP ADAPTERS

TIP ADAPTERS

FEMALE TAPER TO MALE PIPE THREAD					
#130 Code No.	Male Pipe Thread	Female Taper	Stock Size	Length Under Head	Overall Length
	A	B	C	D	E
AP-H24A-8 *	3/8			3/4	1
AP-H24B-7 *					7/8
AP-H24B-8					1
AP-H24B-10	1/2	4 RW	1	5/8	1-1/4
AP-H24B-12					1-1/2
AP-H24B-16					2
AP-H24B-20					2-1/2
AP-H24B-24					3
AP-H24C-7 *	5/8				7/8
AP-H24C-8					1
AP-H25A-13	3/8			3/4	1-5/8
AP-H25B-7 *					7/8
AP-H25B-8					1
AP-H25B-10	1/2	5 RW	1	5/8	1-1/4
AP-H25B-12					1-1/2
AP-H25B-16					2
AP-H25B-20					2-1/2
AP-H25B-24					3
AP-H25C-7 *	5/8				7/8
AP-H25C-8					1

EXAMPLE OF PART CODING:		
AP	=	PIPE THREAD
H	=	HEX STOCK
R	=	ROUND STOCK
2	=	CLASS 2 COPPER
4	=	#4 RW TAPER
A	=	3/8" MALE PIPE THREAD
B	=	1/2" MALE PIPE THREAD
C	=	5/8" MALE PIPE THREAD
D	=	3/4" MALE PIPE THREAD
8	=	LENGTH IN 1/8" INCREMENTS

#130 Code No.	Male Pipe Thread	Female Taper	Stock Size	Length Under Head	Overall Length
	A	B	C	D	E
AP-H35D-11*					1-3/8
AP-H35D-12					1-1/2
AP-H35D-16		5 RW			2
AP-H35D-20					2-1/2
AP-H35D-24	3/4		1-1/4	7/8	3
AP-H36D-11*					1-3/8
AP-H36D-12					1-1/2
AP-H36D-16		6 RW			2
AP-H36D-20					2-1/2
AP-H36D-24					3

* Denotes Minimum Length Available

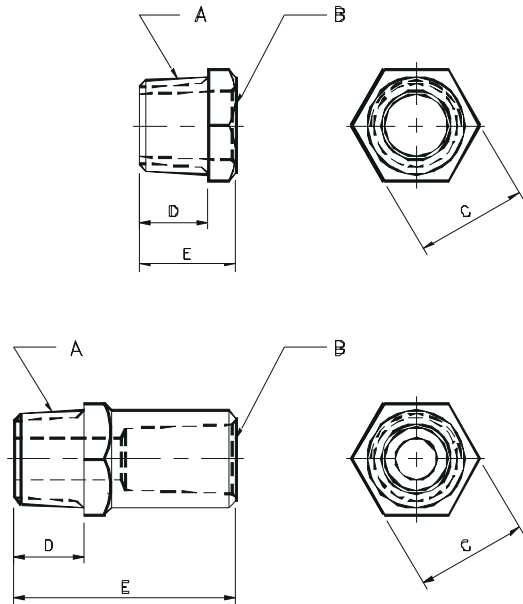

TAPER ADAPTER

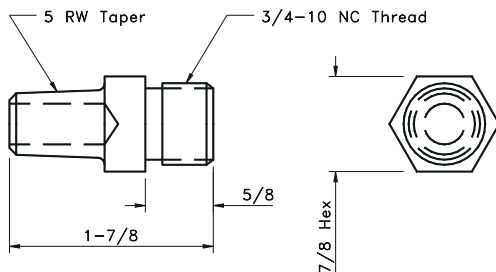

810408-A