

## UNIVERSAL TAPERED BARREL HOLDER ASSEMBLY

ASSEMBLY PART NO.	"T" CONNECTION				HOLDER			ADAPTER HEAD			
	Part No.	Hole Dia.	Shank Dia.	Shank Length	Part No.	Body Dia.	Taper	Part No.	Angle of Head	Taper to Holder	Taper to Electrode
T-1099	T-1159	7/8	7/8	4	T-5405	7/8	5 RW Taper (#2 MT)	T-1190	90 Deg.	5 RW Taper (#2 MT)	4 RW
T-1100	T-1160	1	1		T-5406	1		T-1190			4 RW
T-1125	T-1161	1-1/4	1-1/4		T-5407	1-1/4		T-1290			5 RW
T-1200	T-1163	1	1-1/4		T-5406	1		T-1130	4 RW		
T-1250	T-1164	1	1-1/2		T-5406	1		T-1230	5 RW		



### HOLDER ADAPTER HEADS

#### MALE TAPER TYPE

Part Number	Degree of Angle	Holder Taper	Electrode Taper
T-1190	90	5 RW	4 RW
T-1290	90	Taper (#2 MT)	5 RW
T-1130	30		4 RW
T-1230	30		5 RW

Straight Tapered Barrel holders are shown on page 31.

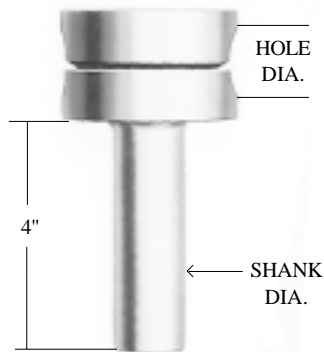

### "T" CONNECTIONS FOR HOLDERS

Part Number	Hole Dia.	Shank Dia.	Shank Length
T-1159	7/8	7/8	4
T-1160	1	1	
T-1161	1-1/4	1-1/4	
T-1162	1-1/2	1-1/2	
T-1163	1	1-1/4	
T-1164	1	1-1/2	
T-1165	1-1/4	1-1/2	

SPECIAL SHANK DIAMETERS ARE AVAILABLE.