

STUD & NUT ELECTRODES

STUD ELECTRODES - SPECIAL 7RW TAPER			
PART # ALLOY #130	PART # ALLOY #130 WITH T-10W FACE	STUD SIZE & DIA.	
T-201	T-201-CT	#8	.164 DIA.
T-202	T-202-CT	#10	.190 DIA.
T-203	T-203-CT	#12	.216 DIA.
T-204	T-204-CT	1/4	.250 DIA.
T-205	T-205-CT	5/16	.312 DIA.
T-206	T-206-CT	3/8	.164 DIA.
T-207	T-207-CT	7/16	.164 DIA.

Also available in metric sizes.

SELF PILOTING NUT ELECTRODES - SPECIAL 7RW TAPER				
PART # ALLOY #130	PART # ALLOY #130 WITH T-10W FACE	NUT SIZE	PIN DIA	PILOT PIN HEIGHT
T-211	T-211-CT	#8-32	.126 DIA.	3/16
T-212	T-212-CT	#10-24	.144 DIA.	3/16
T-213	T-213-CT	#12-24	.170 DIA.	1/4
T-214	T-214-CT	1/4-20	.187 DIA.	5/16
T-215	T-215-CT	5/16-18	.250 DIA.	5/16
T-216	T-216-CT	3/8-16	.312 DIA.	3/8
T-217	T-217-CT	7/16-14	.355 DIA.	3/8
T-218	T-218-CT	1/2-13	.414 DIA.	3/8

STUD ELECTRODES - 5RW TAPER		
PART # ALLOY #130	PART # ALLOY #130 WITH T-10W FACE	STUD SIZE & DIA.
T-501	T-501-CT	#8 .164 DIA.
T-502	T-502-CT	#10 .190 DIA.
T-503	T-503-CT	#12 .216 DIA.
T-504	T-504-CT	1/4 .250 DIA.

SELF PILOTING NUT ELECTRODES - 5RW TAPER				
PART # ALLOY #130	PART # ALLOY #130 WITH T-10W FACE	NUT SIZE	PIN DIA	PILOT PIN HEIGHT
T-511	T-511-CT	#8-32	.126 DIA.	3/16
T-512	T-512-CT	#10-24	.144 DIA.	3/16
T-513	T-513-CT	#12-24	.170 DIA.	1/4

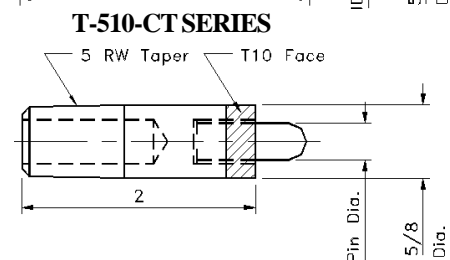
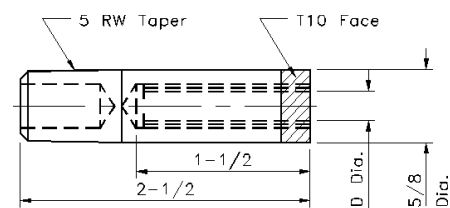
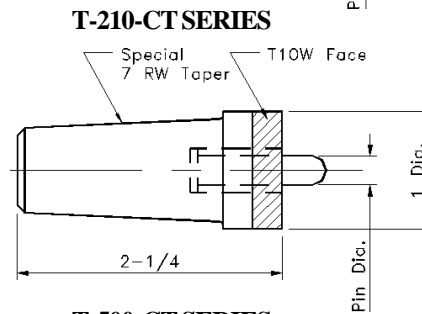
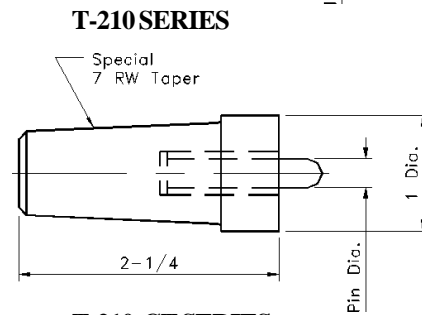
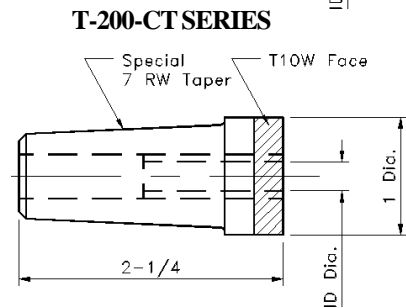
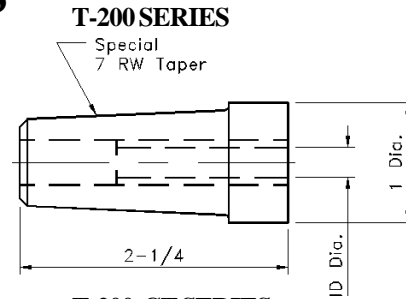

STUD & NUT ELECTRODES